

Vertical Lifting Clamp IP10H

Product information



The IP10H vertical lifting clamps are used for the lifting, turning, moving or vertical transfer of **very hard** (up to 472HV10 (450 HB) sheet, plates, or fabrications, from horizontal to vertical and down to horizontal (180°) as needed. Usually used as a single point pick or when used with a spreader beam with multiple vertical drop lines. Available in a variety of models:

- IP10 - Standard clamp for materials with a surface hardness to 363HV10 (345 HB).
- IP10J - Larger jaw opening.
- IP10S - For use with Stainless Steel material.
- IP10H - For use with materials with a surface hardness to 472HV10 (450 HB).

Features:

- Available in capacities of 0.5 thru 25 metric tons
- Higher Working Load Limits are available upon request.
- Wide variety of jaw openings available: 0 to 60 mm.
- Welded alloy steel body for strength and smaller size. Forged alloy components, where required.
- Individually Proof Tested to 2 times the Working Load Limit with certification.
- User manual and test certificate included with each clamp.
- Full 180° turning range for material transfer, turning or moving.
- Lock open, lock closed ability with latch for pretension on material and then release of material.
- Maintenance and repair kits are available.
- All sizes are RFID EQUIPPED.

... [Read more](#)

Material: Alloy steel.

Marking: According to standard, CE-marked, WLL, Logo, Jaw opening, Serial number

Temperature range: -40°C up to +100°C

Standard: EN 13155

Warning: A minimum load of 10% of the WLL is required.

Vertical Lifting Clamp IP10H

Blueprint

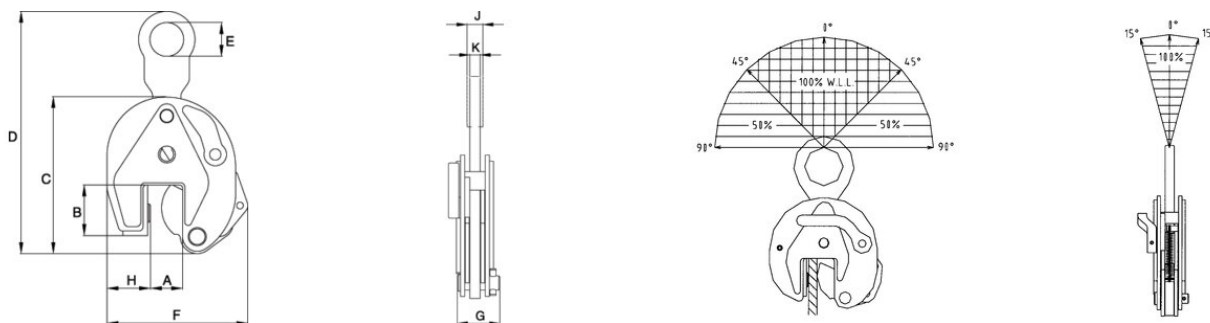

Technical data

Part code	WLL ton	Jaw width mm	Model	A mm	B mm	C mm	D mm	E mm	F mm	G, mm	H, mm	J mm	K mm	Weight kg
16.012702174	0.5	0-16	0.5-IP10H	0-16	44	130	207	40	115	42	28	11	11	1.8
16.012702176	1	0-35	1-IP10H	0-35	78	201	330	70	188	64	55	16	16	7.6
16.012702164	2	0-40	2-IP10H	0-40	100	253	434	75	222	78	60	20	20	13.8
16.012702166	3	0-40	3-IP10H	0-40	100	253	434	75	227	82	65	20	20	15
16.012702168	4.5	0-50	4.5-IP10H	0-50	126	302	517	80	292	84	95	20	20	23.5
16.012702170	6	0-50	6-IP10H	0-50	126	325	544	80	310	92	105	25	25	27.5