

Vertical Lifting Clamp IP10(J)

Product information



The IP10 series vertical lifting clamps are used for the lifting, turning, moving or vertical transfer of sheet, plates, or fabrications from horizontal to vertical and down to horizontal (180°) as needed. Usually used as a single point pick or when used with a spreader beam with multiple vertical drop lines. Available in a variety of models:

- IP10 - Standard clamp for materials with a surface hardness to 363HV10 (345 HB).
- IP10J - Larger jaw opening.
- IP10S - For use with Stainless Steel material.
- IP10H - For use with materials with a surface hardness to 472HV10 (450 HB).

Features:

- Available in capacities of .5 through 30 metric tons
- Higher Working Load Limits are available upon request.
- Wide variety of jaw openings available: 0 to 155 mm.
- Welded alloy steel body for strength and smaller size. Forged alloy components, where required.
- Individually Proof Tested to 2 times the Working Load Limit with certification.
- User manual and test certificate included with each clamp.
- Full 180° turning range for material transfer, turning or moving.
- Lock open, lock closed ability with latch for pretension on material and then release of material.
- For plate surface hardness till 279HV10, only 5% min. WLL is needed.
- Maintenance and repair kits are available.
- All sizes are RFID EQUIPPED.

[... Read more](#)

Material: Alloy Steel.

Marking: According to standard, CE-marked, WLL, Logo, Jaw opening, Serial number

Temperature range: -40°C up to +100°C

Standard: EN 13155

Warning: A minimum load of 10% of the WLL is required. Except for WLL 500 kg which requires a minimum load of 5% of WLL.

Safety factor: 4:1

Vertical Lifting Clamp IP10(J)

Blueprint

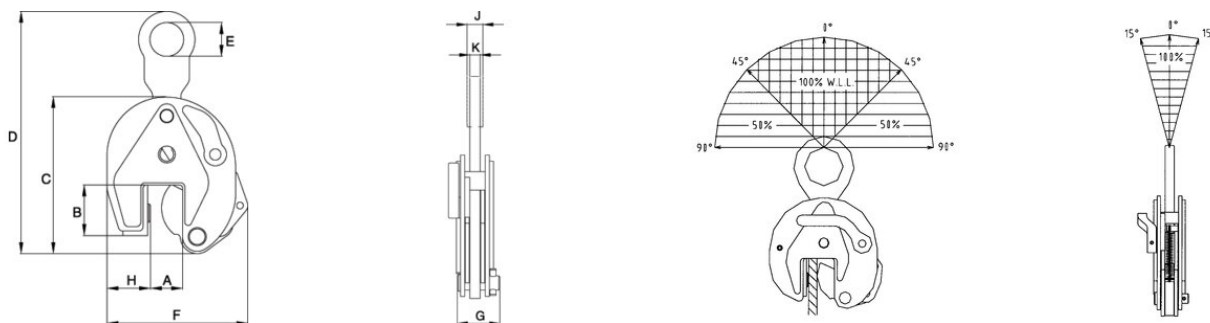

Technical data

Part code	WLL ton	Jaw width mm	Model	A mm	B mm	C mm	D, mm	E mm	F mm	G, mm	H, mm	K mm	J mm	Weight kg
16.012701674	0.5	0-16	IP10	0-16	44	130	203	40	115	42	28	11	-	1.8
16.012701662	1	0-20	IP10	0-20	45	139	212	40	127	42	38	11	-	2.2
16.012701676	2	0-35	IP10	0-35	78	201	330	70	188	64	55	16	-	7.6
16.012701664	3	0-40	IP10	0-40	100	253	434	75	222	78	60	20	-	13.8
16.012701666	4.5	0-40	IP10	0-40	100	253	434	75	227	82	65	20	-	15
16.012701670	9	0-50	IP10	0-50	126	325	544	80	310	94	104	25	44	29.8
16.012701678	12	0-54	IP10	0-54	160	392	574	80	433	121	137	25	41	50.4
16.012701682	16	5-64	IP10	5-64	180	463	686	88	492	121	153	25	45	68
16.012701686	22.5	5-80	IP10	5-80	222	554	803	110	565	153	186	25	49	108
16.012701690	30	5-80	IP10	5-80	222	554	803	110	565	153	186	30	54	124