

Chain Block Powertex PCB-S2OLP with Corolim® Chain

Product information



POWERTEX

The Powertex PCB-S2 OLP Chain Hoist is a high-quality chain block designed to provide durability, safety, and ease of operation. With its ergonomic hand chain, advanced features, and built-in overload protection, this chain hoist ensures smooth and efficient lifting for various industrial applications. This OLP version has an integrated Overload Protection, which ensures safe lifting and prevents unintended overloading of the hoist.

Product benefits:

Overload protection device: the OLP hoists are factory-equipped with an Overload Protection device, which limits the maximum operating force that can be applied using the hand chain, ensuring safe and controlled lifting operations.

Enhanced safety: each hoist undergoes dynamic proof load testing at 1.5 times the Working Load Limit (WLL) before leaving the factory, ensuring maximum safety and reliability. The hoist is equipped with a well-covered automatic load reaction brake and features double safety with two brake pawls and four brake springs, exceeding EN 13157 requirements. The load chain is calibrated, proof load tested and meets the requirements of EN 818-7.

Smooth and efficient operation: the compact and lightweight construction, combined with a sprocket wheel equipped with needle bearings and a drive shaft supported by needle and slide bearings, ensures smooth and efficient operation. The fine-calibrated European-made COROLIM® protected load chain offers quiet and seamless performance.

Load chain with superior corrosion resistance: the unique COROLIM® surface treatment of the load chain provides excellent corrosion protection, equivalent to ISO944-9 C5High / ISO9223 C3 standards, ensuring I ... [Read more](#)

Material: Durable all steel construction

Marking: According to standard, CE-marked, UKCA-marked, Powertex, Model, WLL, Chain, Serial number, User manual/QR code

Temperature range: -10°C up to +50°C

Finish: Red powder coated body and plated frame components

Standard: EN 13157, EN 818-7

Safety factor: 4:1

Chain Block Powertex PCB-S2OLP with Corolim® Chain

Blueprint

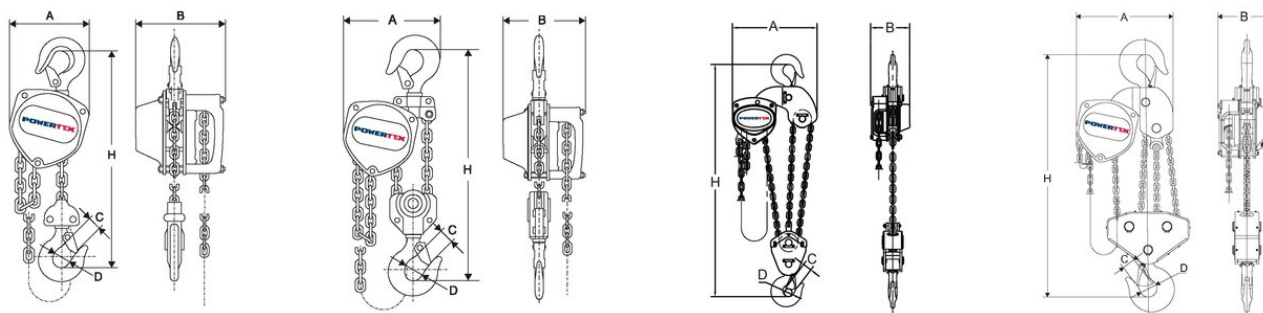

Technical data

Part code	WLL ton	Lifting height m	Number of falls	Model	Load chain mm	Hand chain mm	Hand force max. kg	A mm	B mm	C mm	D mm	H min mm	Weight kg
16.10PCBS20050030OLP	0.5	3	1	PCB-S2OLP/500KG PHC	5,0 x 15,0	5,0 x 23,7	24.9	130	128	22	34	280	9.8
16.10PCBS20050060OLP	0.5	6	1	PCB-S2OLP/500KG PHC	5,0 x 15,0	5,0 x 23,7	24.9	130	128	22	34	280	9.8
16.10PCBS20100030OLP	1	3	1	PCB-S2OLP/1000KG PHC	6,3 x 19,0	5,0 x 23,7	28.4	150	145	26	39	330	11.7
16.10PCBS20100060OLP	1	6	1	PCB-S2OLP/1000KG PHC	6,3 x 19,0	5,0 x 23,7	28.4	150	145	26	39	330	12
16.10PCBS20200030OLP	2	3	1	PCB-S2OLP/2000KG PHC	8,0 x 24,0	5,0 x 23,7	34.3	185	175	35	49	385	18.9
16.10PCBS20200060OLP	2	6	1	PCB-S2OLP/2000KG PHC	8,0 x 24,0	5,0 x 23,7	34.3	185	175	35	49	385	19.5
16.10PCBS20300030OLP	3	3	2	PCB-S2OLP/3000KG PHC	7,1 x 21,0	5,0 x 23,7	34.3	220	158	37	50	510	28.9
16.10PCBS20300060OLP	3	6	2	PCB-S2OLP/3000KG PHC	7,1 x 21,0	5,0 x 23,7	34.3	220	158	37	50	510	28.9
16.10PCBS20500030OLP	5	3	2	PCB-S2OLP/5000KG PHC	9,0 x 27,0	5,0 x 23,7	37.2	255	183	43	60	615	37.1
16.10PCBS20500060OLP	5	6	2	PCB-S2OLP/5000KG PHC	9,0 x 27,0	5,0 x 23,7	37.2	255	183	43	60	615	51.05